



Exceptional service in the national interest

Further investigation of novel shock amplification platform for dynamic material properties

Tommy Ao

PDV Workshop

Washington State University, Pullman, WA
May 19 – 20, 2026

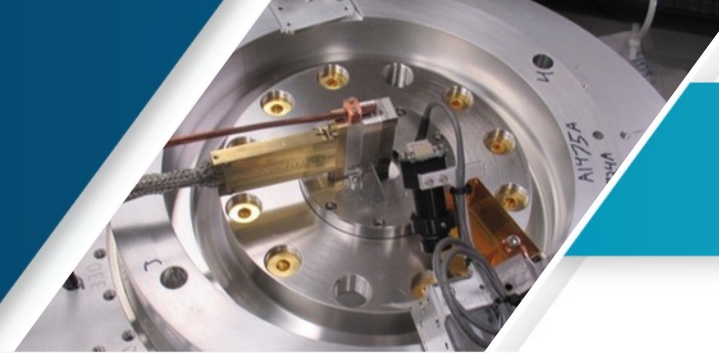
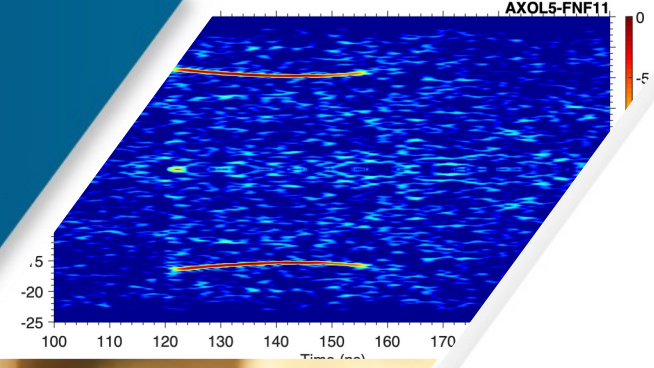
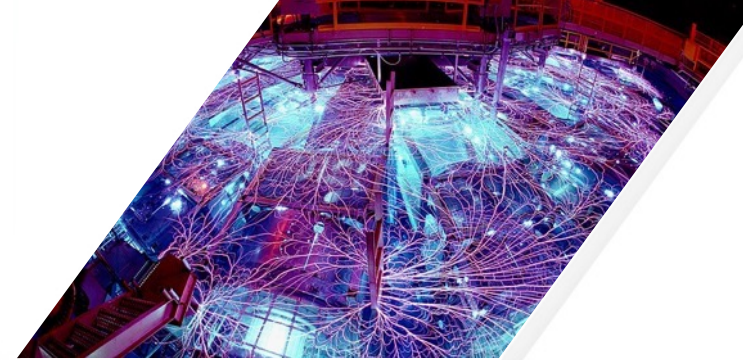

Sandia National Laboratories is a multimission laboratory managed and operated by National Technology & Engineering Solutions of Sandia, LLC, a wholly owned subsidiary of Honeywell International Inc., for the U.S. Department of Energy's National Nuclear Security Administration under contract DE-NA0003525.

SAND2026-20973C

Background and motivation



“ZEndor: a shock amplification EOS platform for STAR and Z” accepted proposal under Z Fundamental Science (ZFS) program

- Hydrodynamic amplification system to increase attainable pressures from Z Machine driven flyer plates up to ~ 10 TPa over mm scale sample sizes.
- Use established flyer plate and diagnostic hardware isolates amplifier performance and ensures high quality data collection.
- Demonstrate EOS platform on STAR 2-stage gas gun before testing on Z Machine.

Dynamic compression facilities at SNL

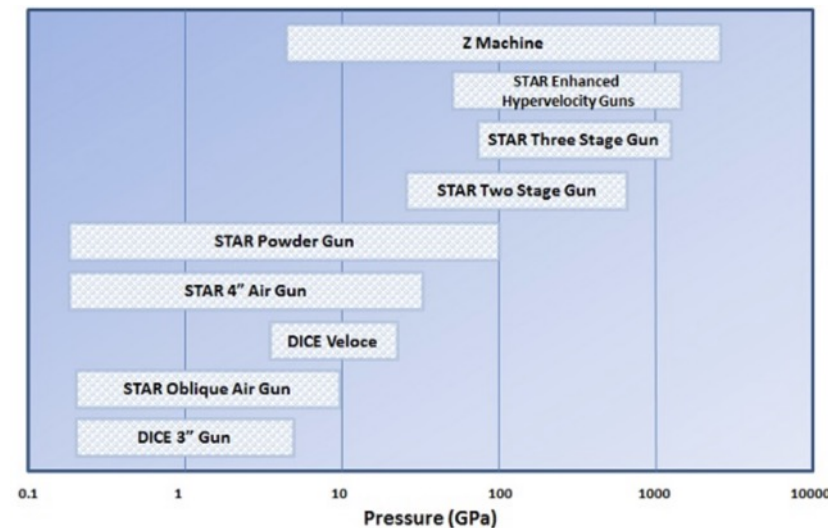
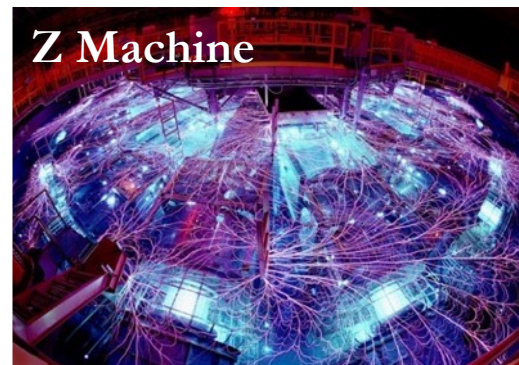

Shock pressure amplification

Two distinct processes are combined to increase shock pressure

1. Shock amplification via Mach reflections.
 - Mach reflections sequentially form between the anvil walls and symmetry axis.
2. Shock reflections along the z-axis in addition to the channel walls to increase the output shock pressure.
 - This z-folding (or shock multiplexing) is achieved using alternating layers of high and low impedance material.

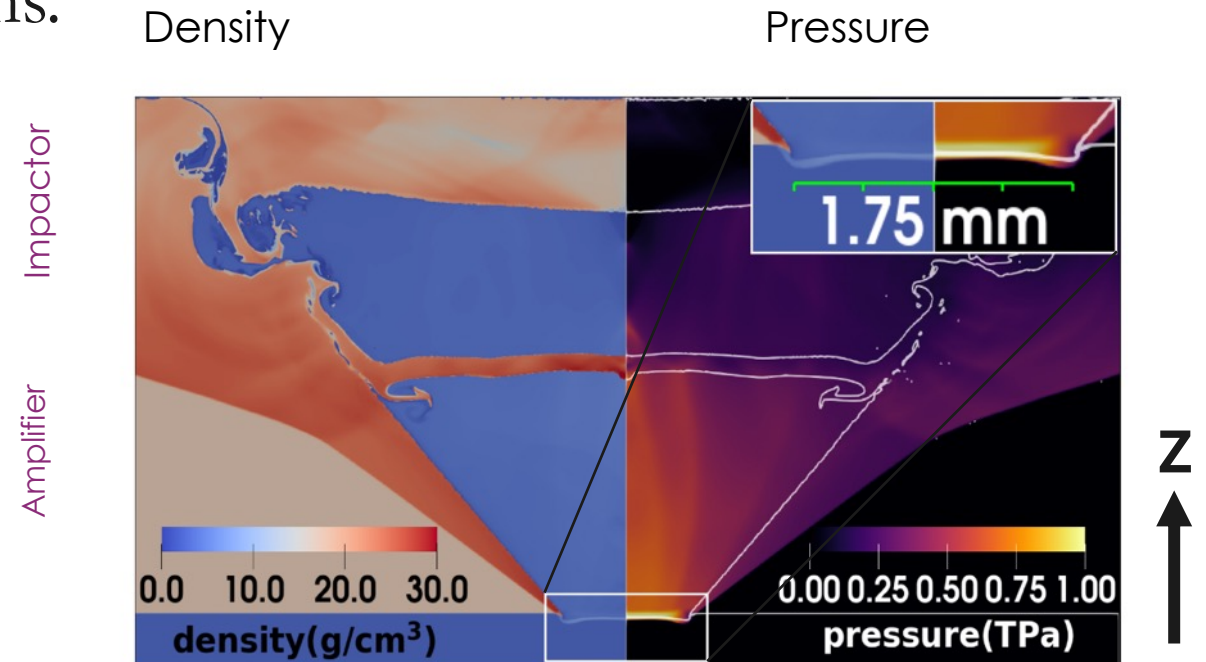

Due to number of degrees of freedom, numerical optimisation is required.

STAR: Initial validation of Endor-3 amplifier

Experimental setup on STAR 2-stage gas gun

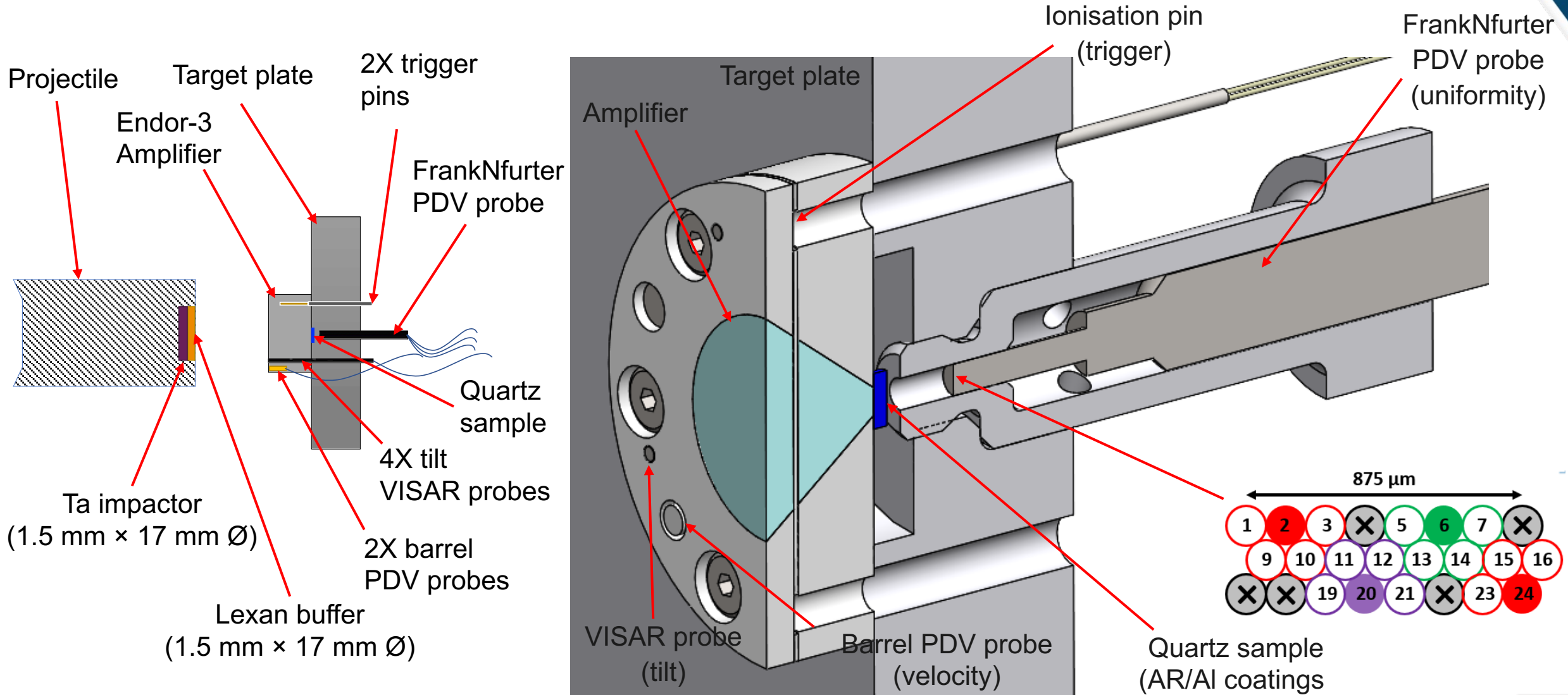

STAR: PDV setup of Endor-3



Laser parameters

- 4 target lasers and 4 reference lasers: 1549, 1549, 1550, 1554 nm
- Downshifted PDV: -21 and -32 GHz

Linear array (FrankNfurter) probes

- 24 fibers, stacked 3 rows by 8 columns
- 0.125 mm spacing

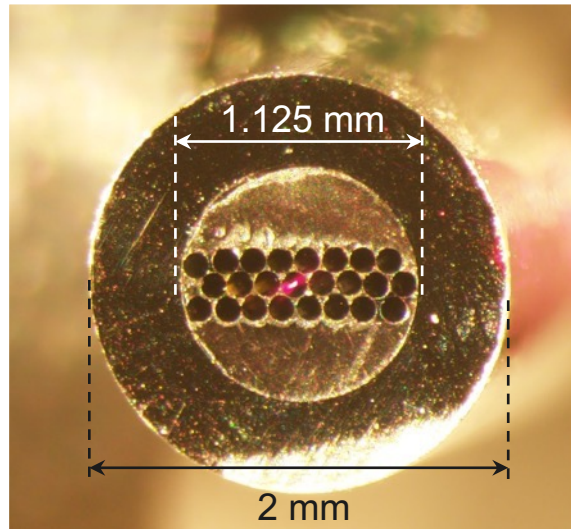
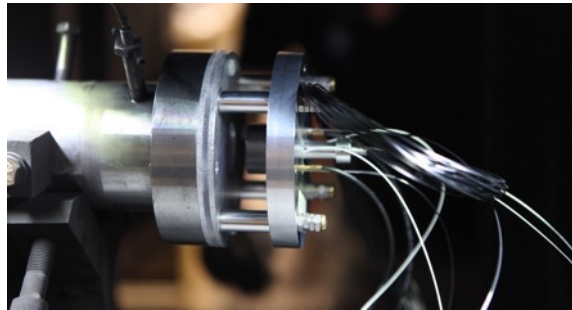

FrankNfurter window probe configuration

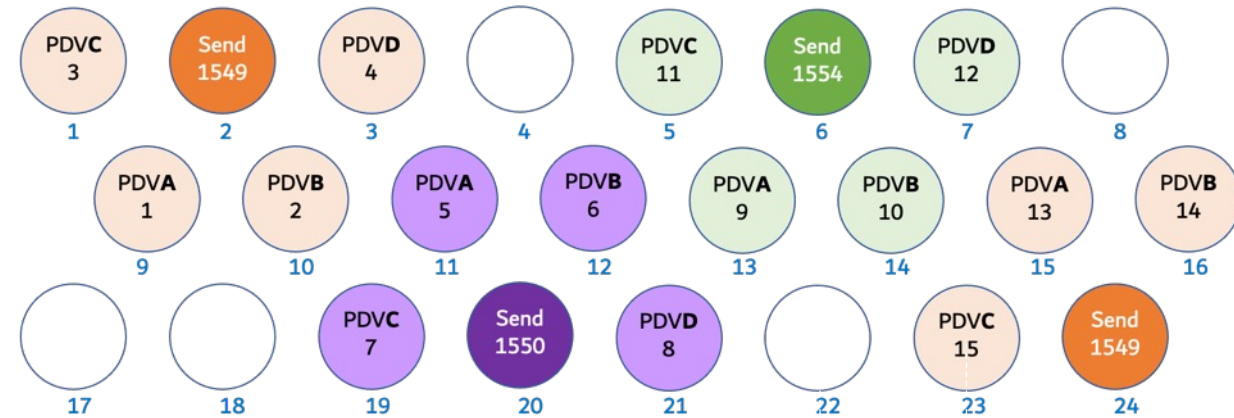

Scope A - PDVA
Scope B - PDVB
Scope C - PDVC
Scope D - PDVD

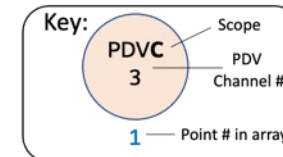

STAR: PDV measurements of Endor-3

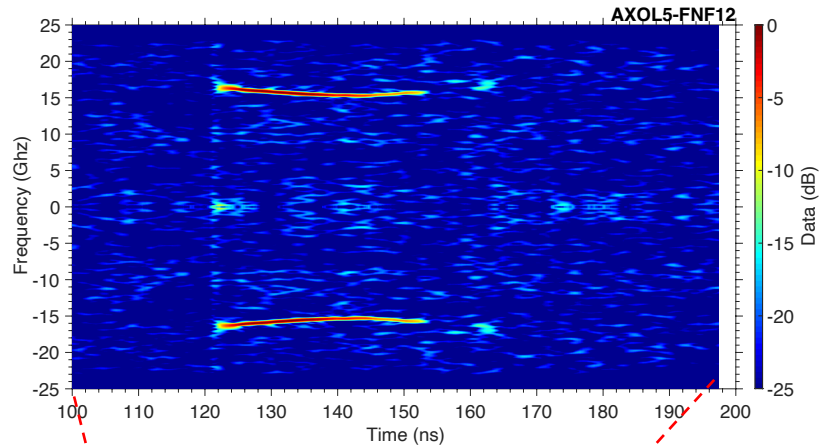
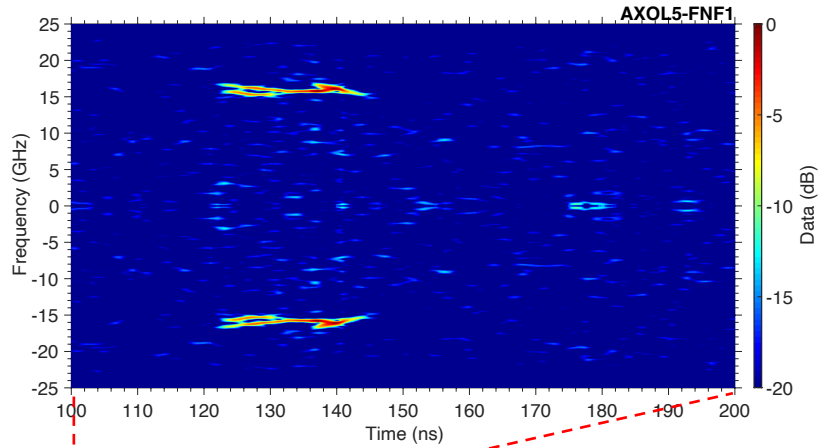

Target	Endor
Projectile	Ta/Lexan
Impact velocity	6.56 km/s
Tilt	2.9 mrad (0.17°)

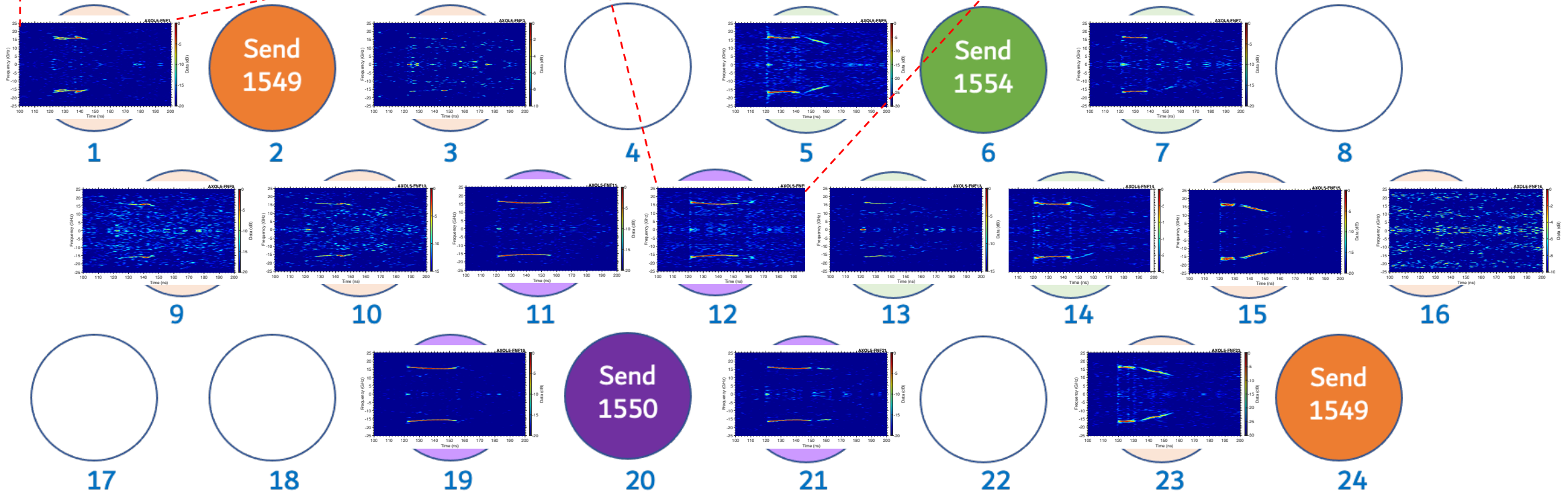

STAR: Results of Endor-3



Measured amplifier performance

- 1.6% temporal uniformity within each measurement in 10 ns requirement
- 1.2% variation in spatial uniformity between probes

Quartz shock velocity	25.1 ± 0.2 km/s (25.7 km/s simulated)
Quartz pressure	1085 GPa (1040 GPa simulated)
Direct impact quartz pressure	142 GPa (@ 6.56 km/s)
Pressure gain	7.6X
Planar area	$0.75 \pm 0.4/0.05$ mm
Temporal hold	~ 20 ns (2%)

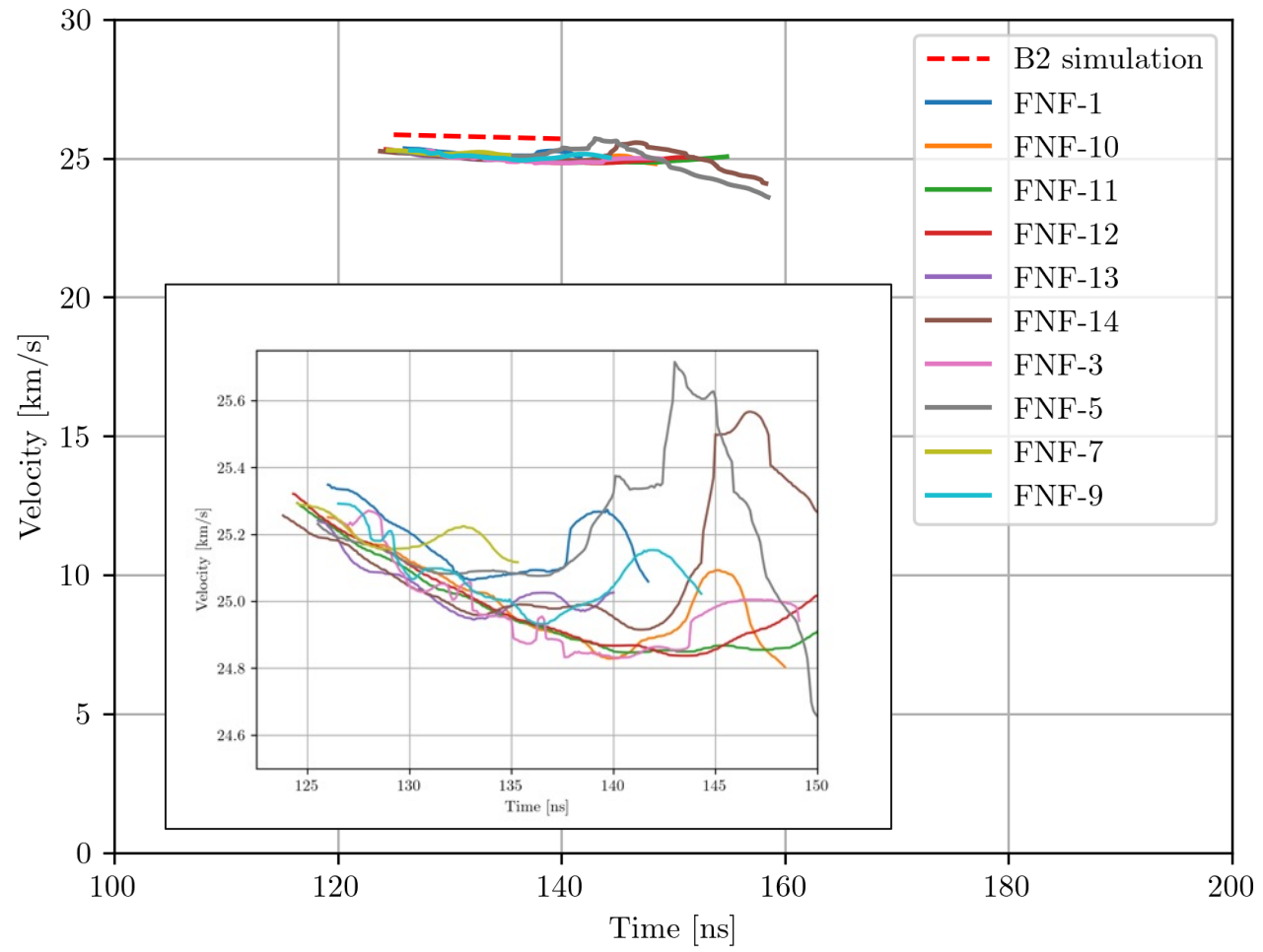

STAR: Endor-4 amplifier with split sample to measure EOS

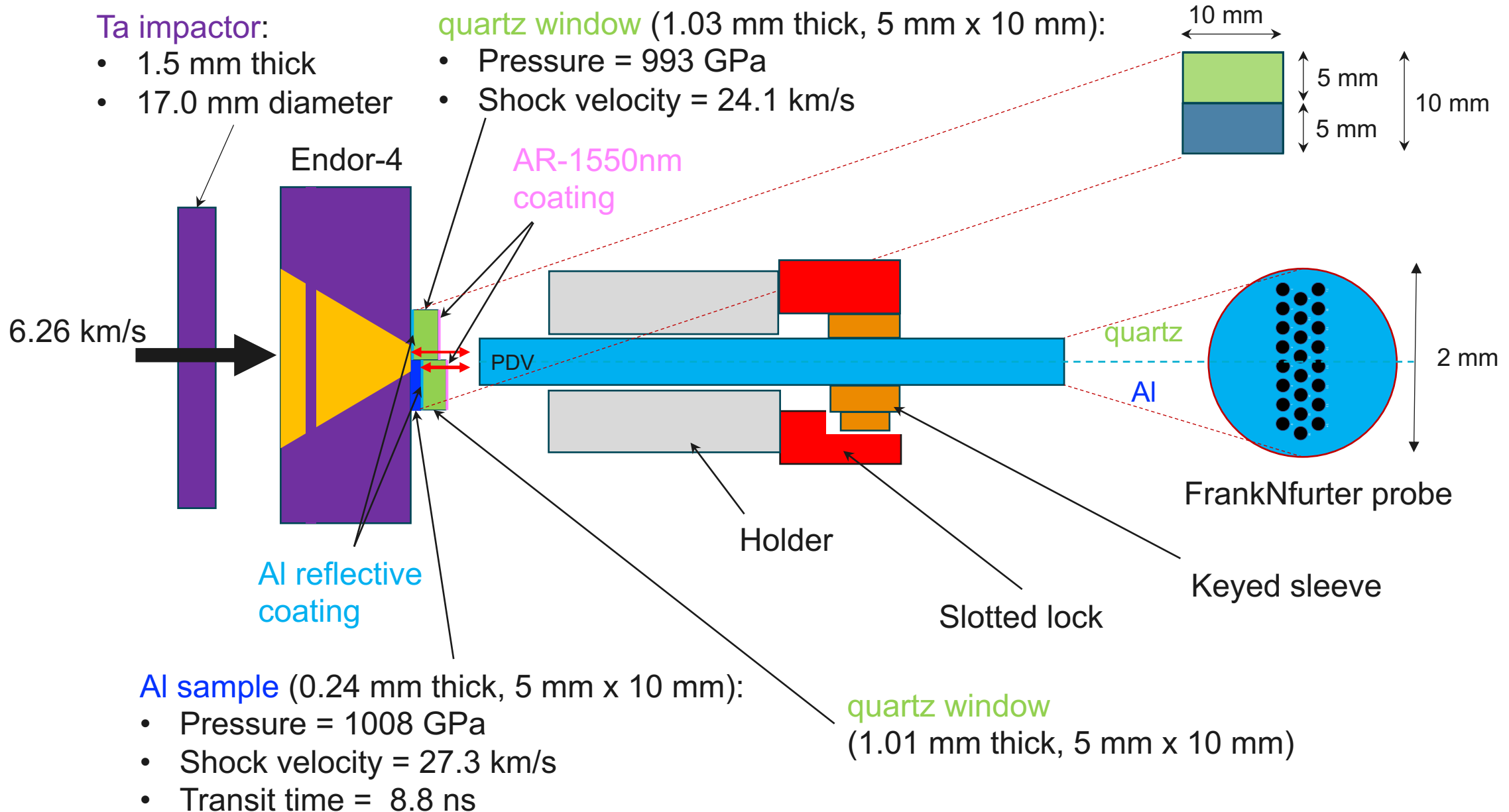

STAR: Experimental setup of split sample on Endor-4



quartz window
(1.03 mm thick)

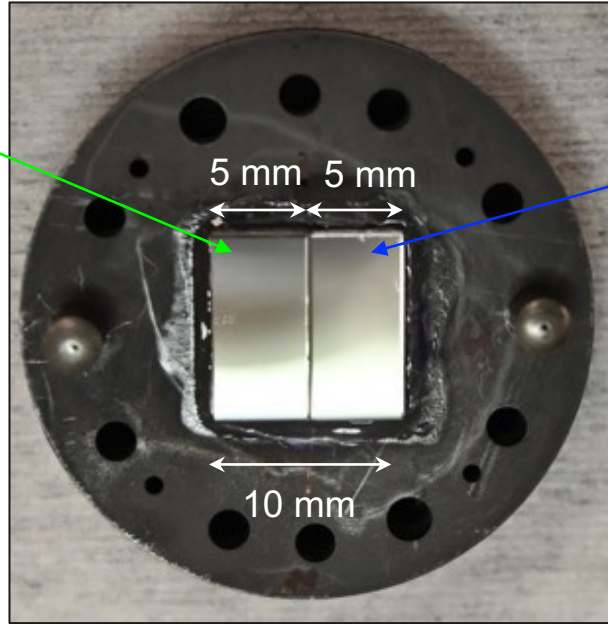

Al sample
(0.24 mm thick)

quartz window
(1.01 mm thick)

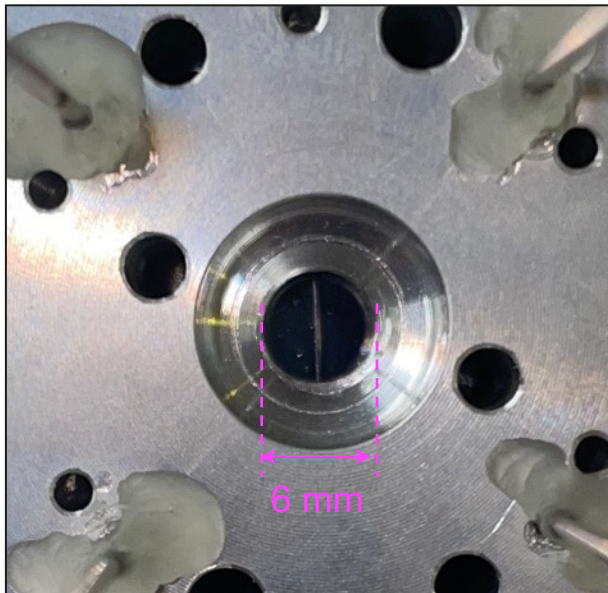
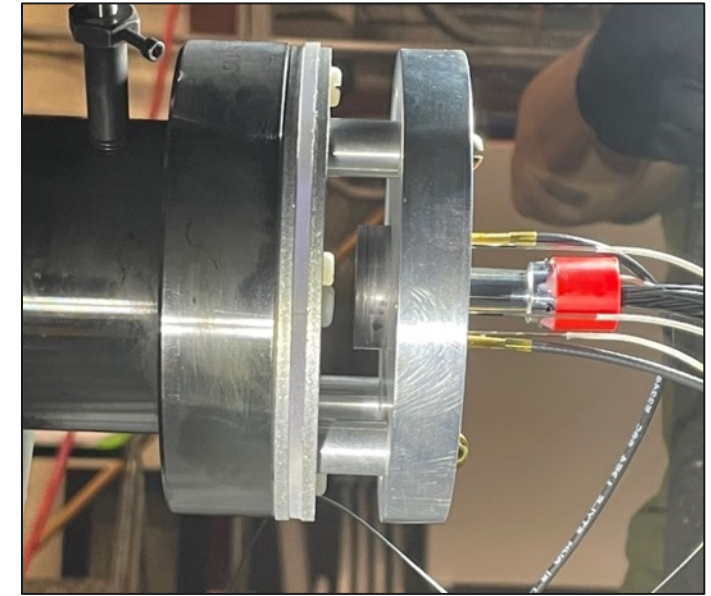

Slotted lock

Keyed sleeve

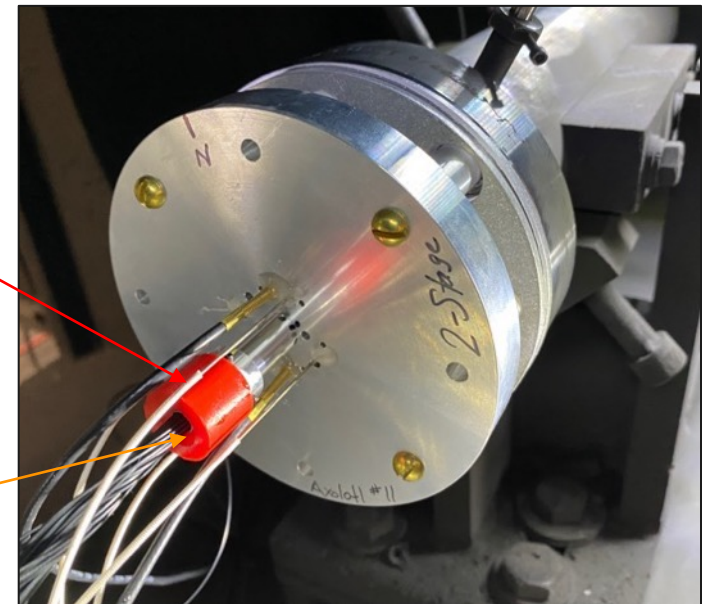

STAR: PDV setup of Endor-4



Laser parameters

- 4 target lasers and 4 reference lasers: 1549, 1549, 1550, 1554 nm
- Downshifted PDV: -33 GHz, Upshifted PDV: 2 GHz

Linear array (FrankNfurter) probes

- 24 fibers, stacked 3 rows by 8 columns
- 0.125 mm spacing

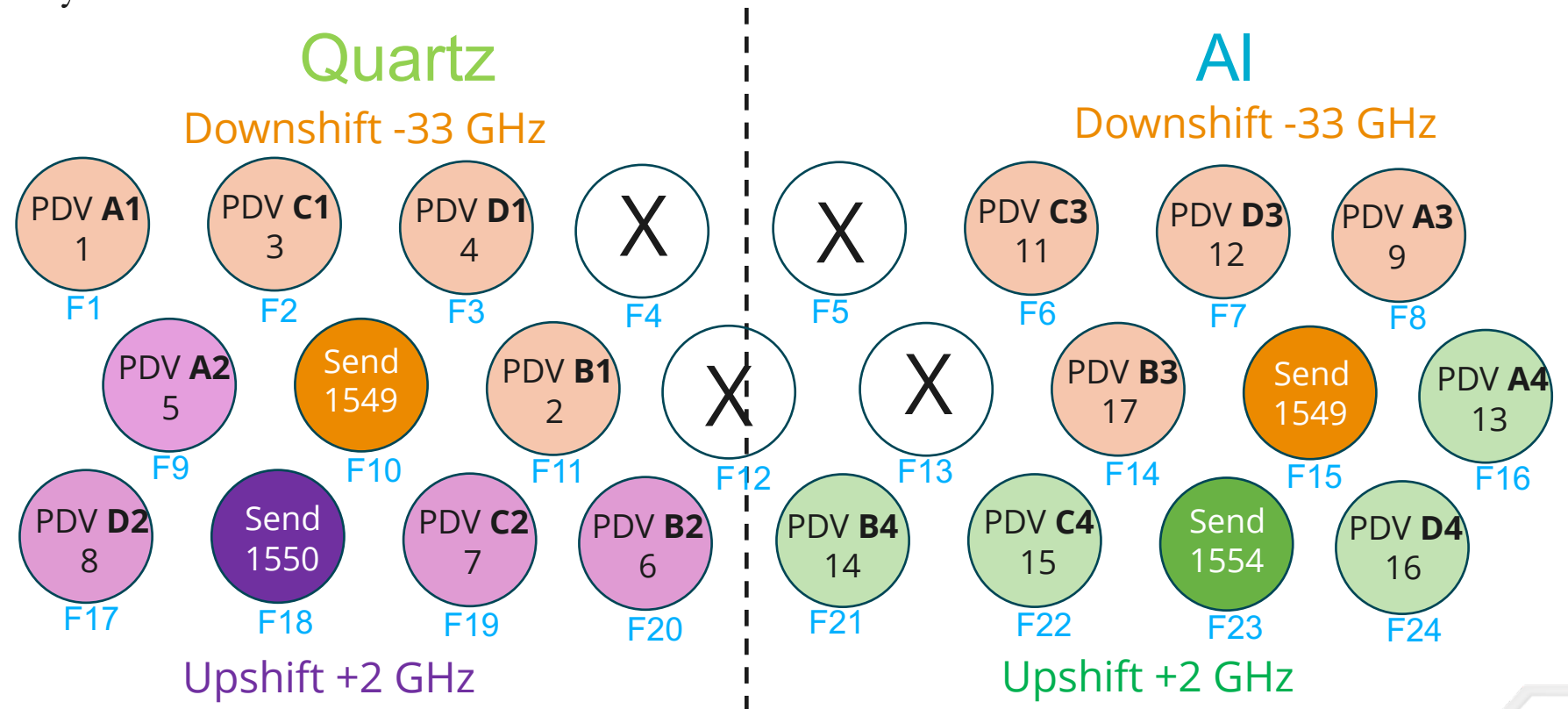
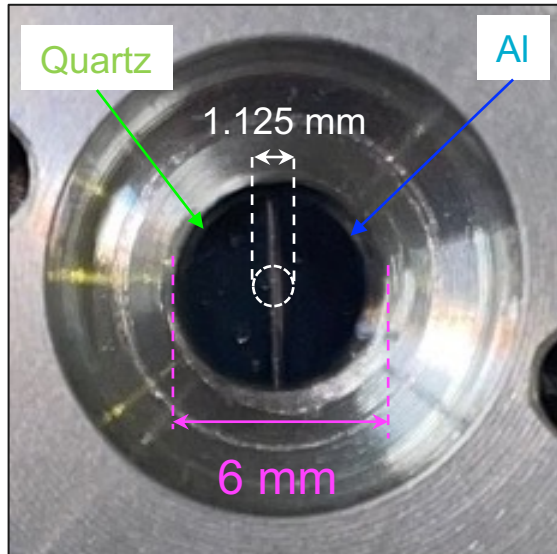

STAR: PDV measurements of Endor-4

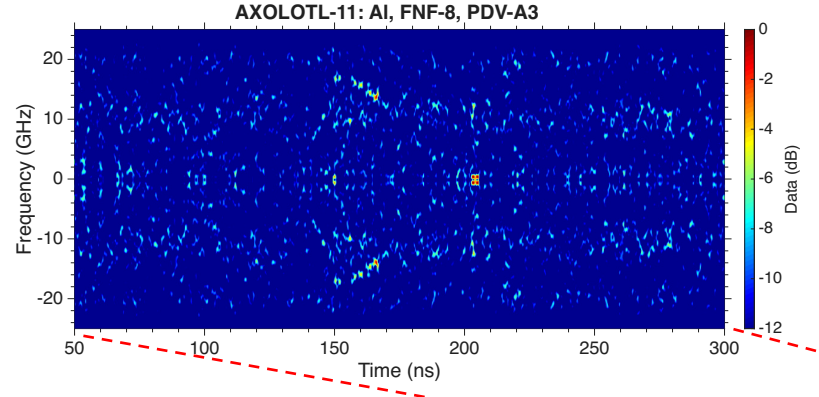
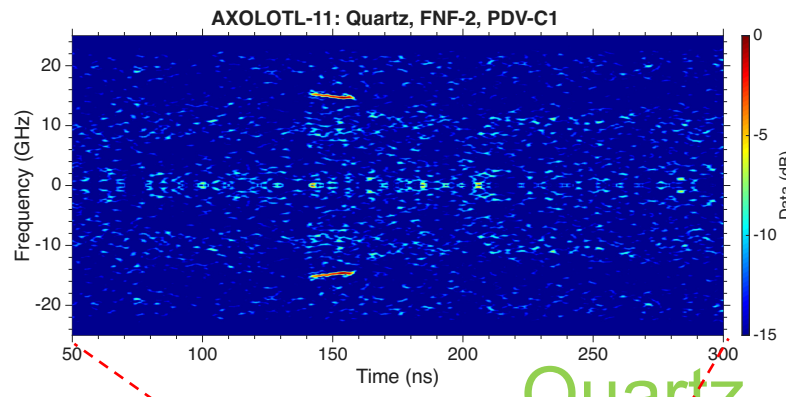

Target	Endor-4
Projectile	Ta
Impact velocity	6.26 km/s

Quartz

Al

Downshift -33 GHz

Downshift -33 GHz

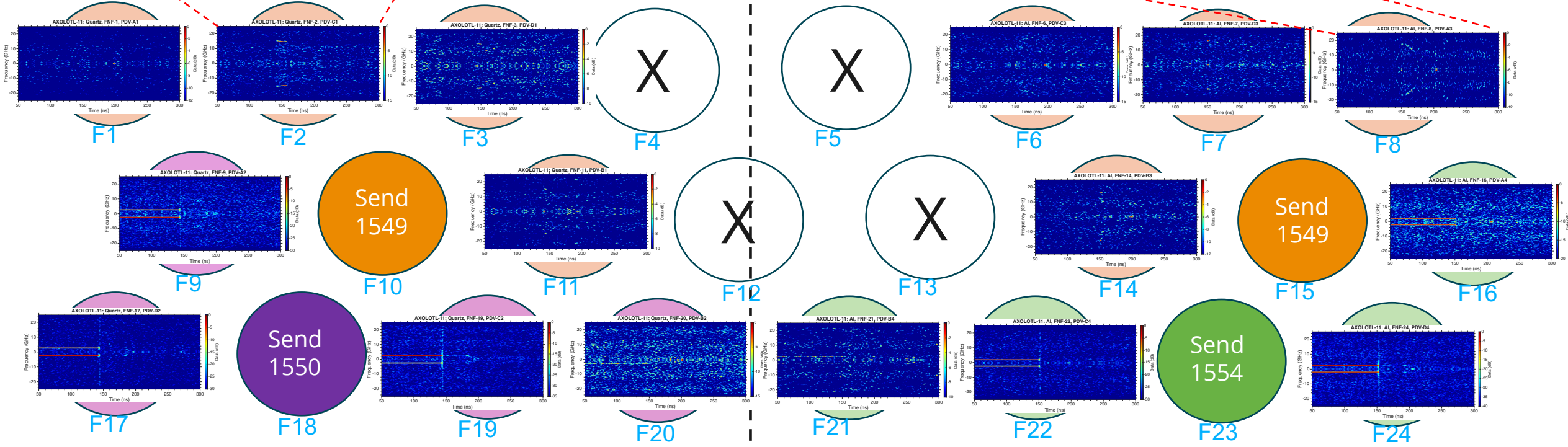

Send 1549

Send 1549

Send 1550

Send 1554

Upshift +2 GHz

Upshift +2 GHz

STAR: Results of Endor-4



Transit times between upshifted channels

- Show effect of edge waves from center line of split sample

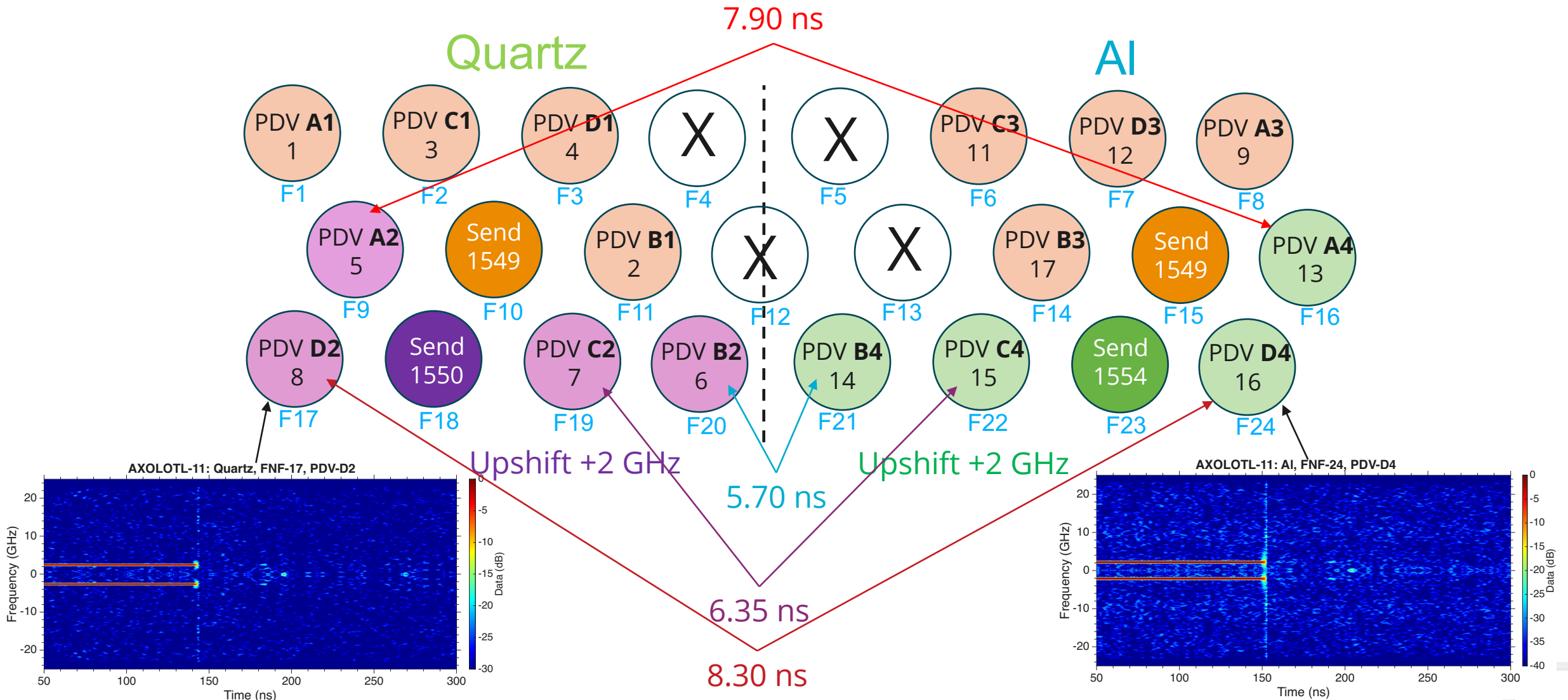

STAR: Results of Endor-4



Shock velocities from downshifted channels

- Direct comparison between quartz drive and Al sample

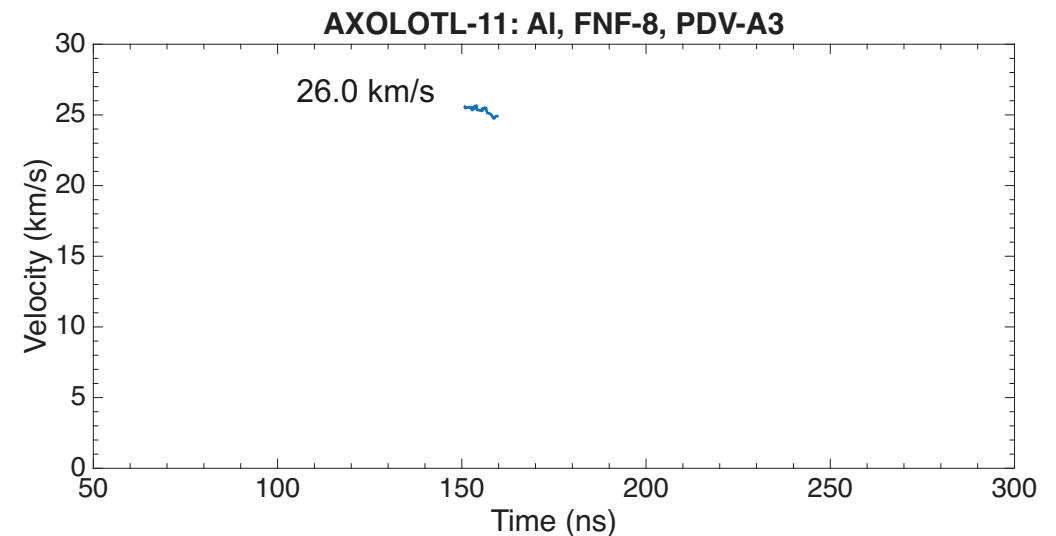
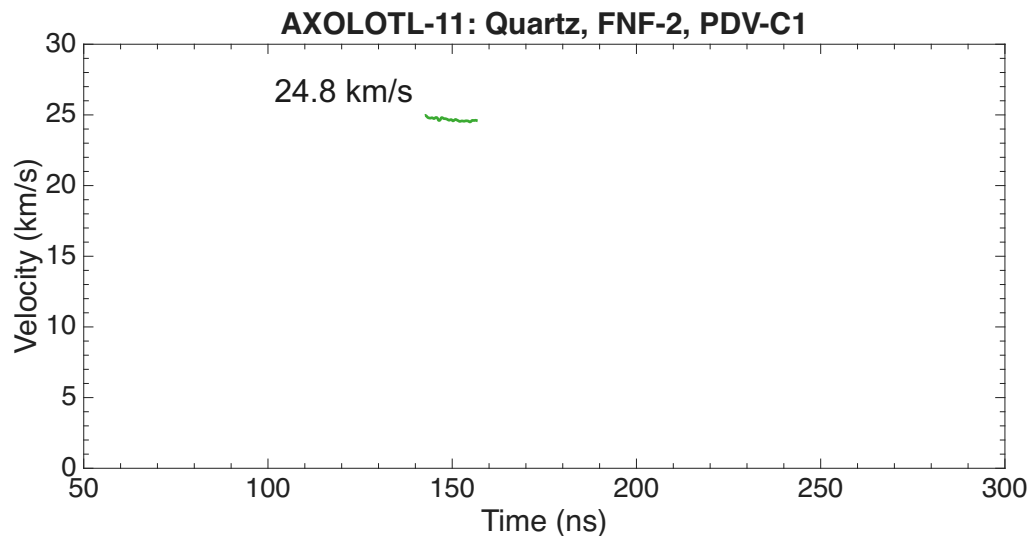
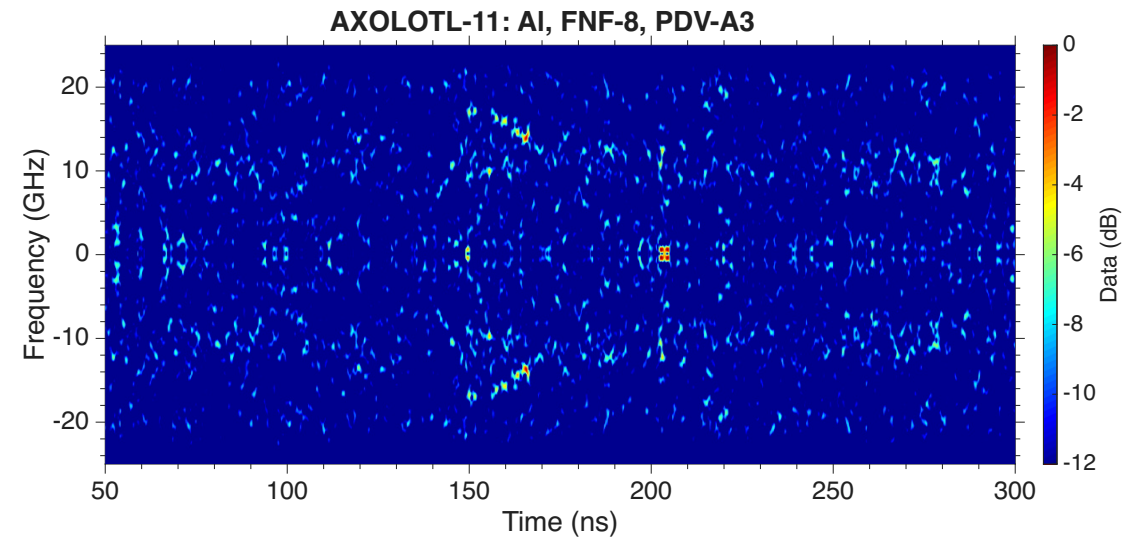
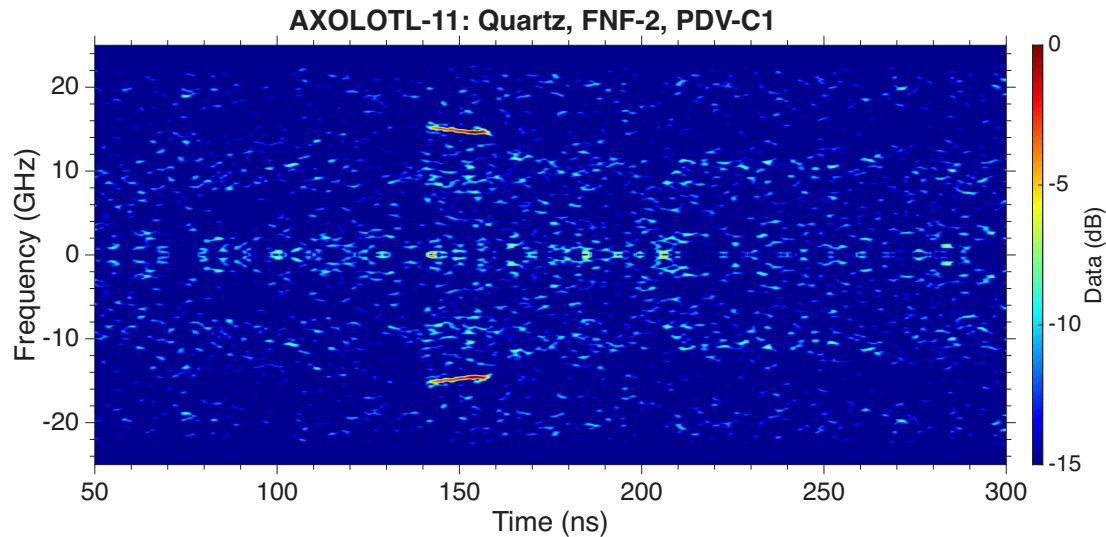

Z: Validation of amplifiers using Z-DMP load on Z3956



Experimental setup

- Pre-existing flyer configuration to limit risk to amplifier at cost of pressure multiple
- “31/kms” Al flyer imparts ~920 GPa impact on quartz, aim to double this pressure
- Modify amplifier to match flyer impact conditions
- 4 amplifiers along flyer length
 - 2 distinct amplifier designs
- Primary diagnostics all commissioned fiber-based velocimetry

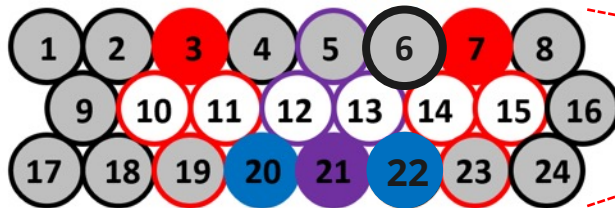
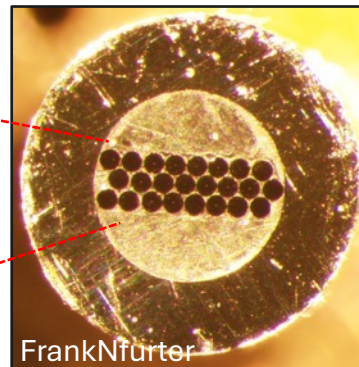
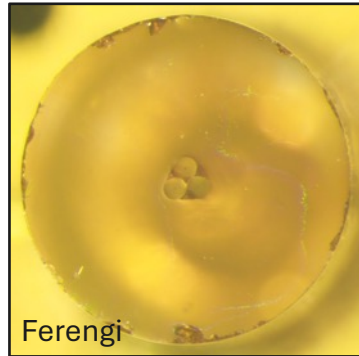
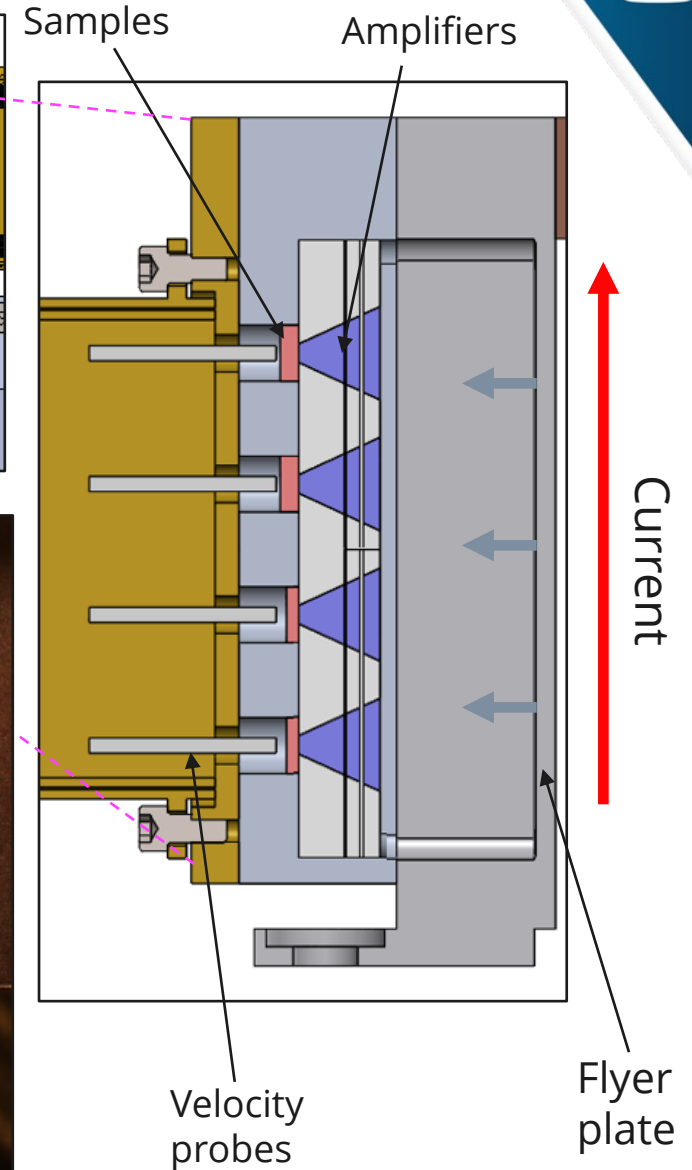
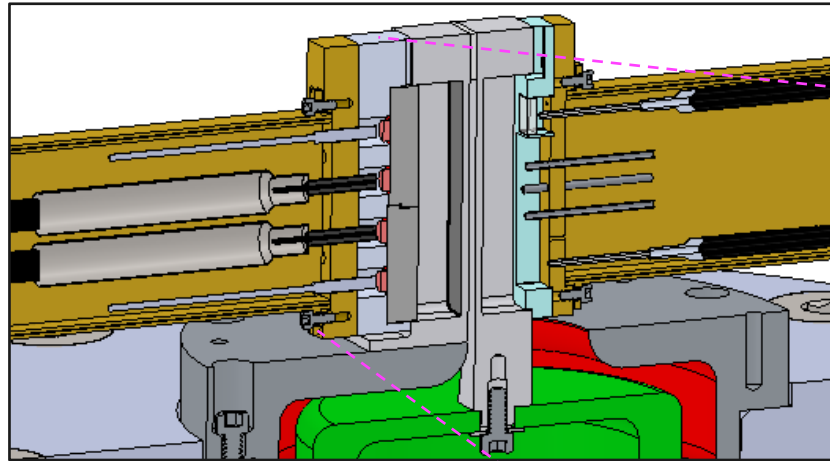

Z: PDV measurements on Z3956

Flyer performed within expectations

- Quartz pressure amplified to 1.63 TPa (1.68X gain)
- Some PDV data in the null point (0 GHz)
- Edge effects on probes 14 and 15

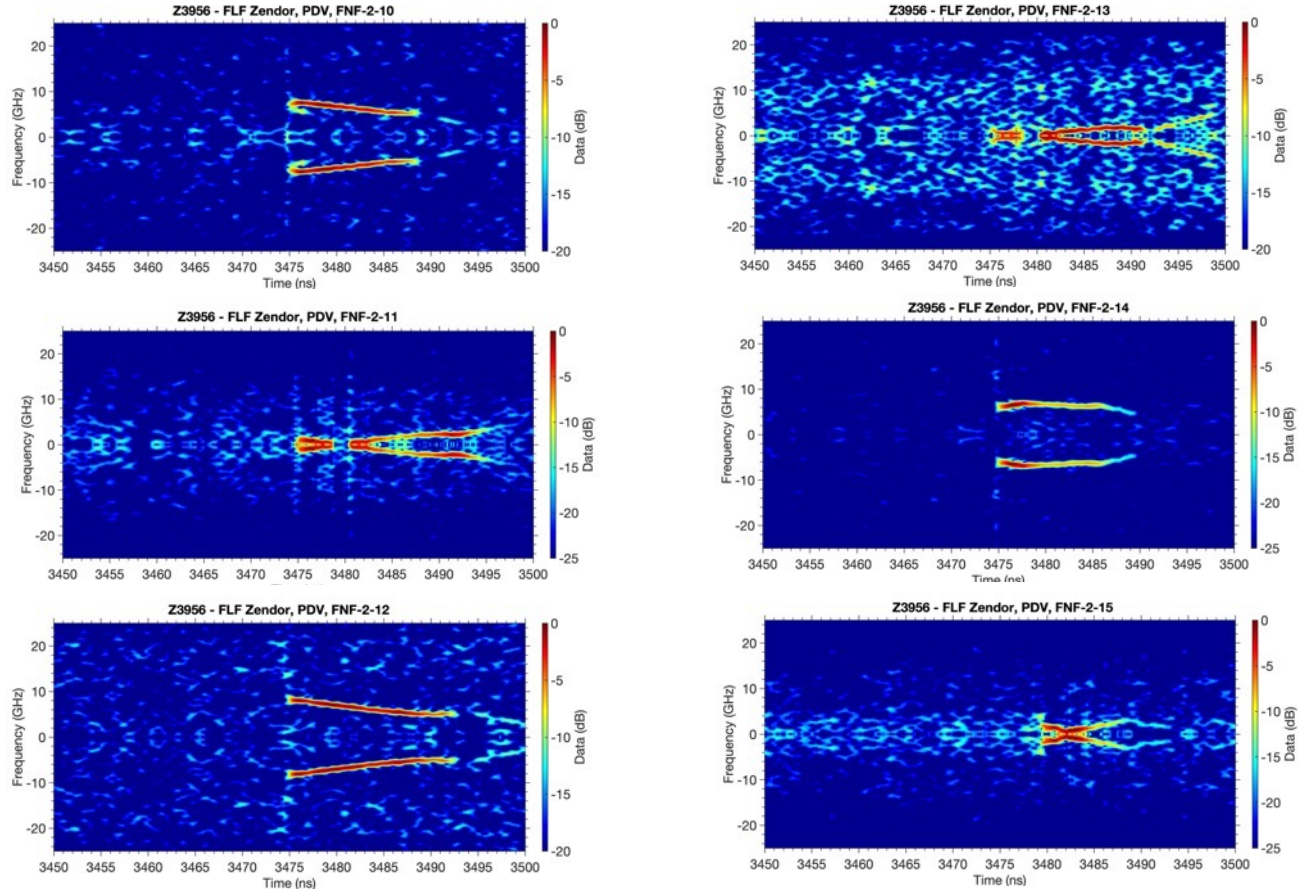

Quartz shock velocity [km/s]	30.26 ± 0.125
Quartz Pressure [TPa]	1.63 ± 0.02
Direct Impact pressure [TPa]	0.970
Pressure multiple	1.68
Planar Area [mm]	0.375 ± 0.13/0.05
Temporal hold [ns]	[2 %] 10 ns

Quartz shock velocity (Endor amplifier)

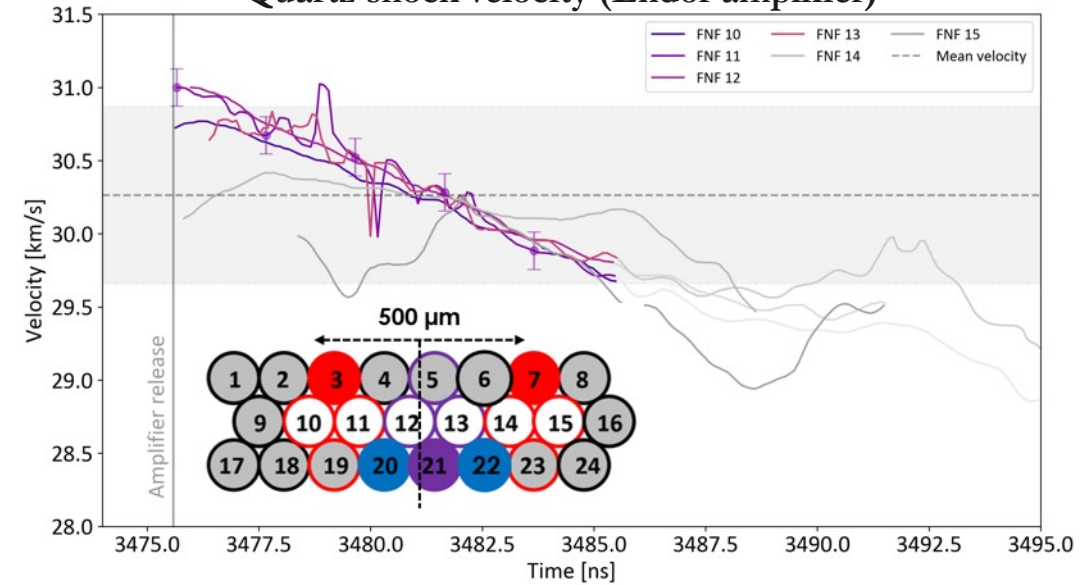

Z: Increase pressure drive of amplifiers on Z4110



Asymmetric Load

- 45 km/s Al flyer, thick W cathode stalk

Diagnostics

- Multi-point PDV and VISAR for flyer impact and amplifier output
- Radiography to assess flyer stability, density profile and gap clearing
- B-dot to determine B-drive temporal profile

Quartz EOS measurement

- Determine quartz Hugoniot data point via impedance matching (IM) with Al standard
- Quartz shock velocity measured directly
- Al shock velocity measured via transit time

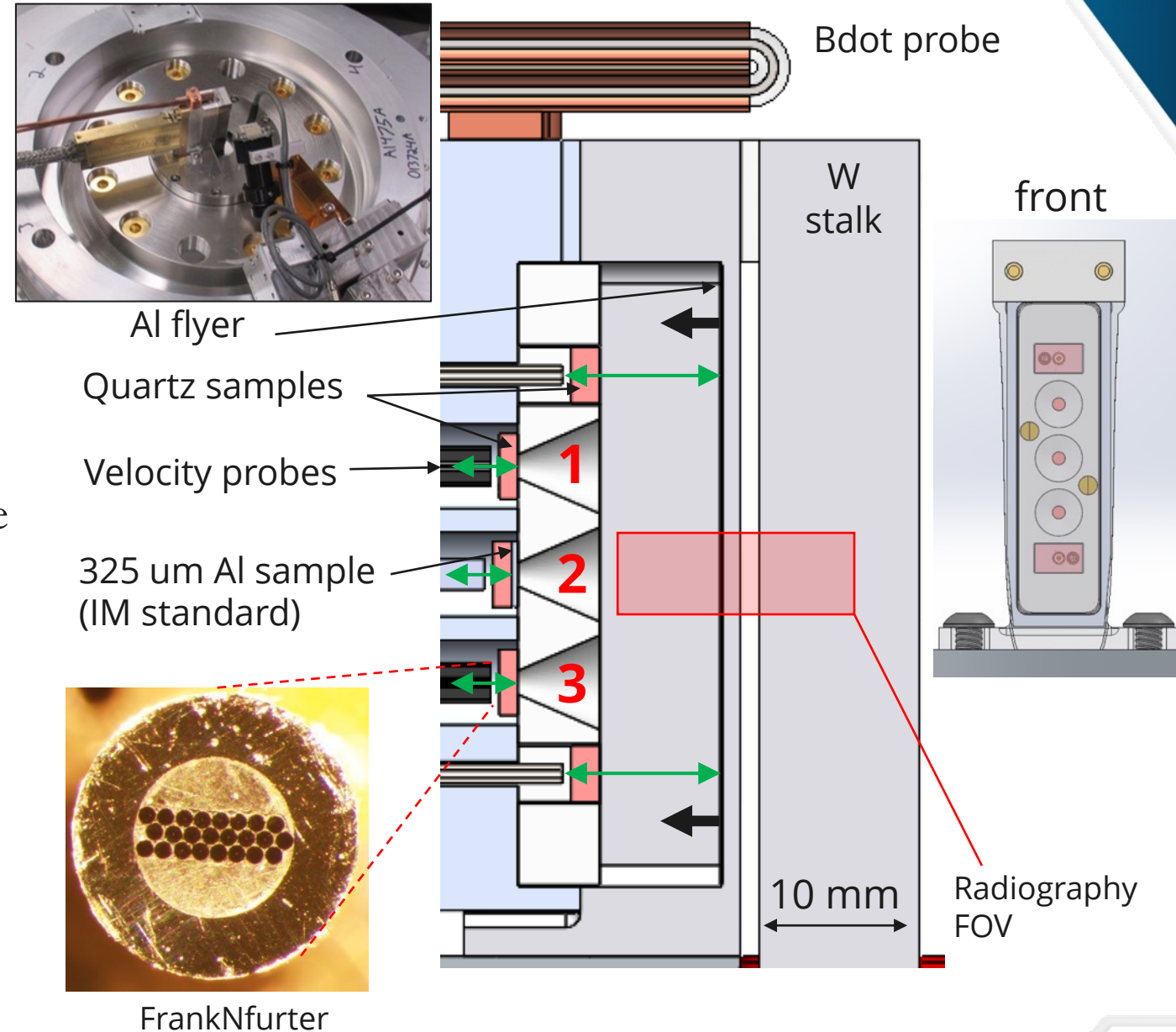

Z: PDV measurements of Z4110

Measured amplifier performance

- Z4110 doubled quartz pressure (3.6 TPa) for same hold time and spatial extent, compared to Z3956
- Pressure and hold time in good agreement with simulations
- Challenge: Lost 11 out of 18 amplifier velocity probes!

Quartz shock velocity [km/s]	43.6
Quartz Pressure [TPa]	3.6 TPa
Planar Area [mm]	~ 0.5 mm
Temporal hold [ns]	[2 %] >10 ns

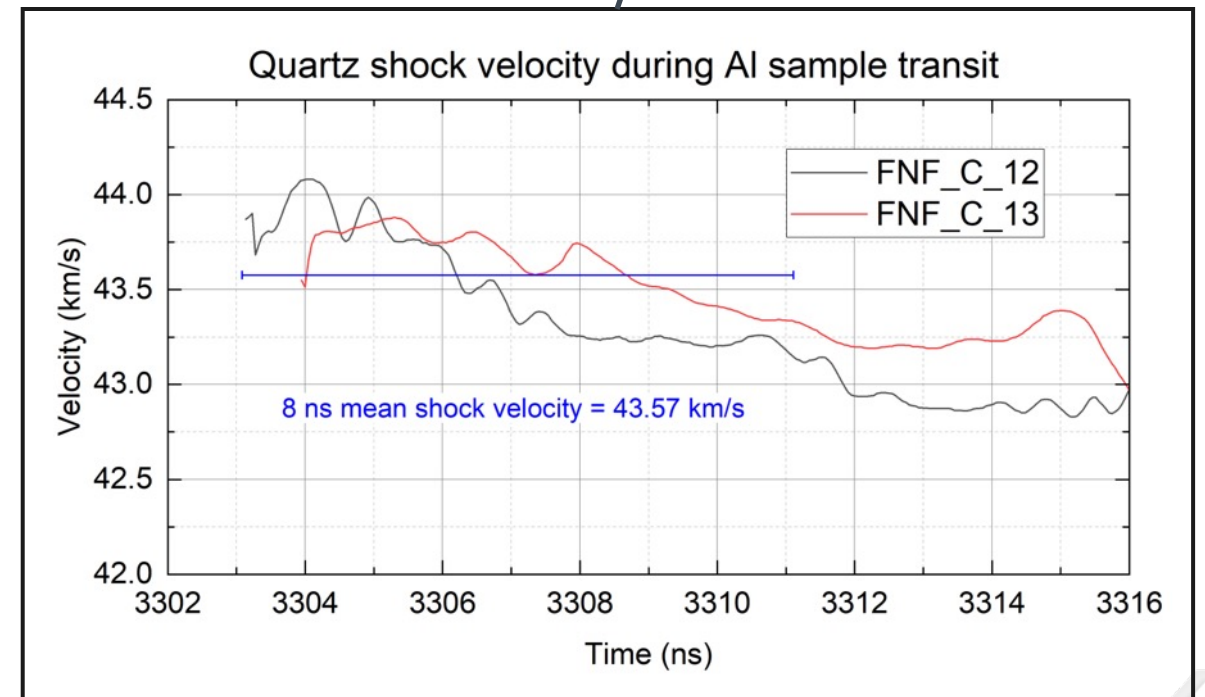
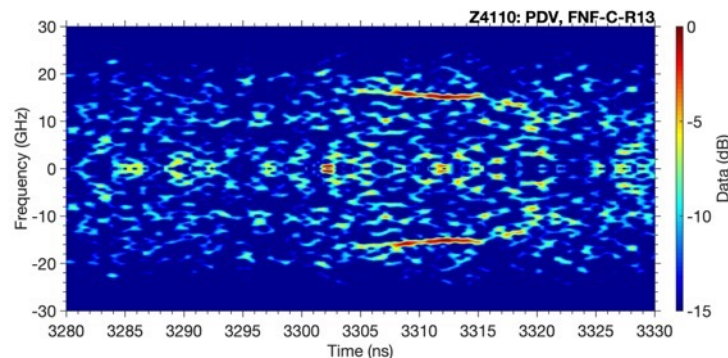
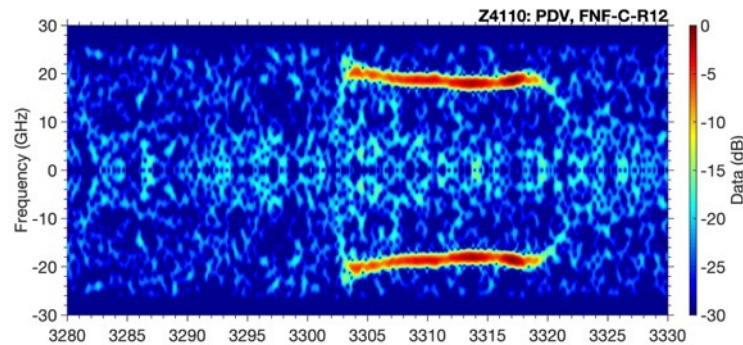
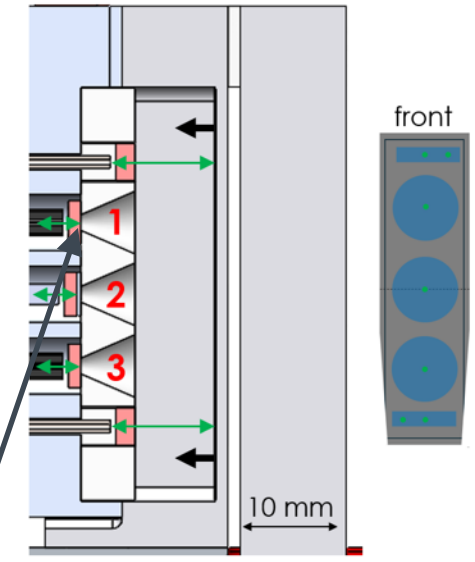

Z: Quartz EOS measurement on Z4110



Determine quartz Hugoniot data point via impedance matching with Al standard

- Quartz shock velocity measured directly
 - 43.6 km/s for 8 ns
- Al shock velocity measured via transit time
 - Data point obtained via comparison across 3 amplifiers
 - $\tau_{Al} = 7.70 \pm 0.1$ ns (0.1 ns limit on PDV timing resolution)
 - 0.1 ns = 1.3 % (4.7 % in density)
 - Error budget is under investigation
- **Preliminary analysis** suggests a stiffer quartz response compared to previous data

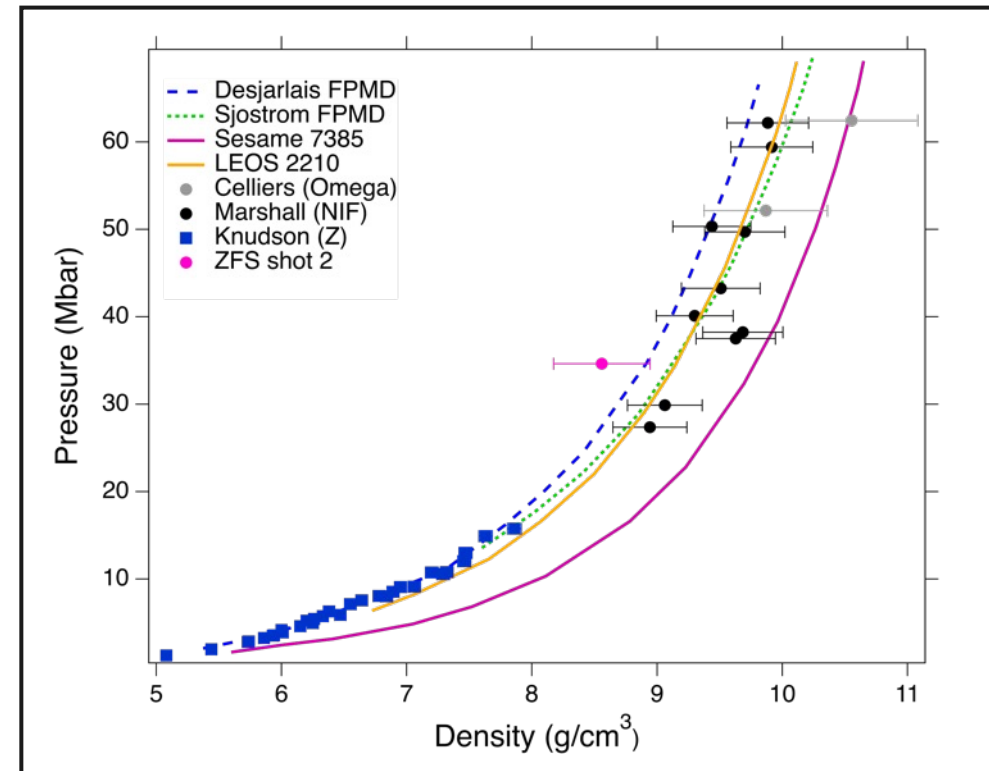

Z: Radiography measurements on Z4110



First image of Z-DMP flyer propagation

- Development of bubbles and spikes
- Density profile appears more extended than in simulations
- AK gap looks clear (at 7.2 keV)
- Challenging to model (3D, vapour dome, kinetic effects)

Frame 1 – 3183.6 ns (time of impact)

White is transmission

Flyer plate moves to the right

Al transmission cutoff at $\sim 1\%$ solid density

Flyer trailing mass Impact plane

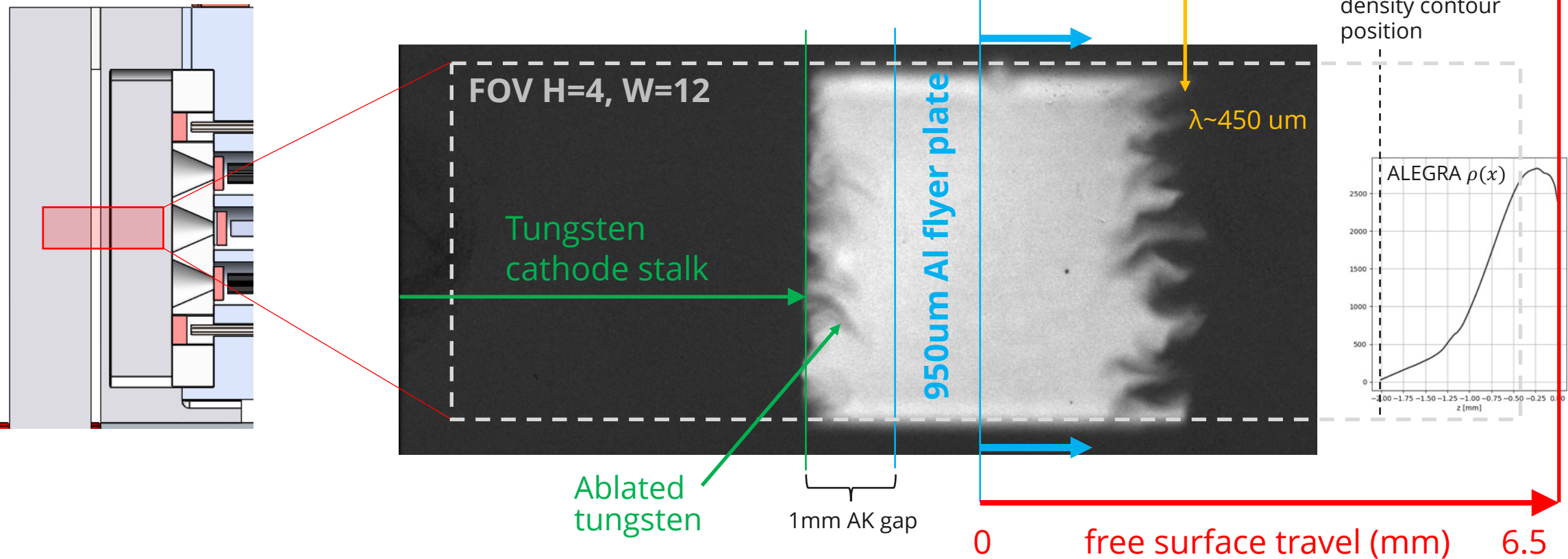

Z: B-dot measurement on Z4110



First look at magnetic field near Z-DMP load

- Prototyped a Bdot measurement above the shorting cap
 - ~1mm radius loop calibrated against a Helmholtz pair and Hall probe
 - Non-perturbative
- 1D flyer profile sensitive to current after peak
- Obtained real data for ~200 ns
- Saturation and breakdown of channel 2

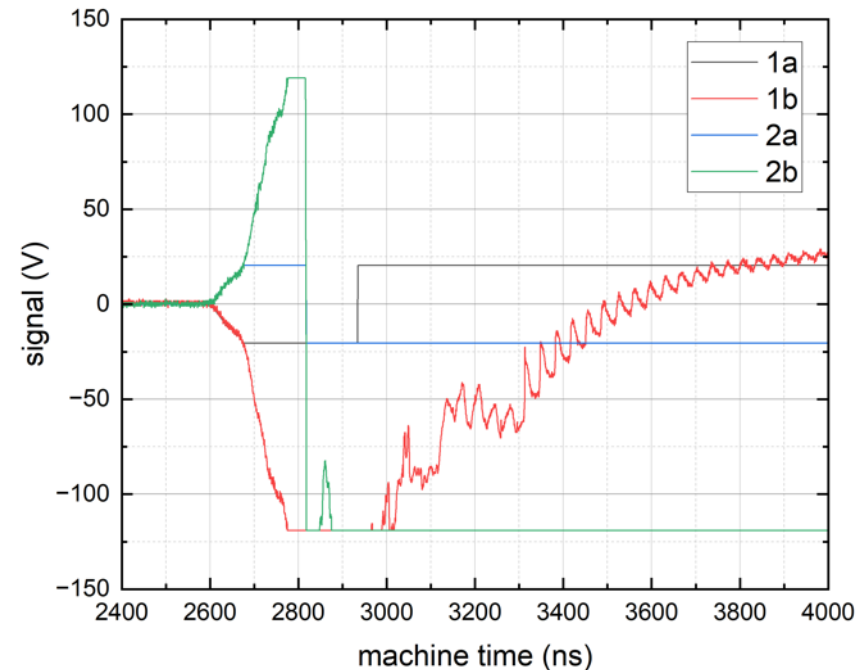
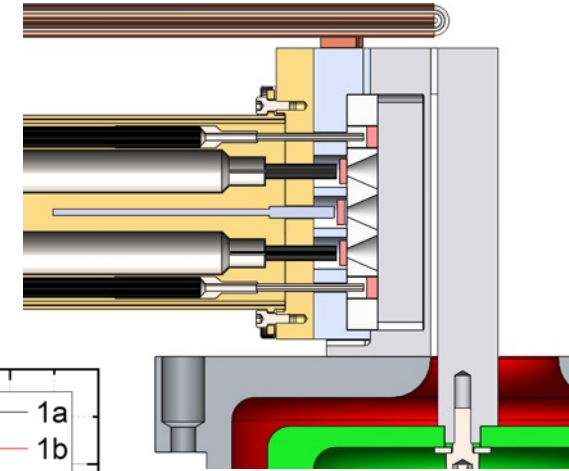
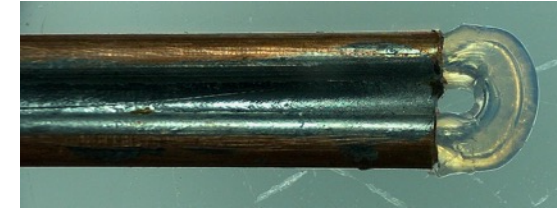

Acknowledgements



- **Sandia National Laboratories**

- Andy Porwitzky, Dan Dolan, Bernardo Farfan, Chris Johnson, Aaron Hansen, Carrie Blada, Heath Hanshaw, Chris Jennings, Justin Brown, Marcus Knudson, Chris Seagle

- **First Light Fusion**

- Jonathon Skidmore, Guy Burdiak, Nicholas Niasse, Victor Martinez, Tim Ringrose, Rafik Silva, Nicholas Hawker